

BH1600AB



THE BH1600AB with all Allen-Bradley controls is the latest model in the BH1600 Series of labelers. The BH1600AB is a value priced linear, roll-fed labeler designed for low to mid-speed operation in demanding production environments. Field proven, running a wide range of applications, the BH1600 Series offers durable and dependable performance which has made it one of the most popular and widely used models ever offered by B & H Labeling Systems.

DEPENDABLE AND AFFORDABLE

BH1600AB labelers are designed to apply full wrap-around labels to containers at steady-state production speeds of up to 450 containers per minute (cpm). Offering reliable operation in continuous, around-the-clock production environments running both full and empty containers, the BH1600AB is widely regarded as a workhorse labeler in a variety of industries.

VALUE IN SIMPLICITY

BH1600AB linear roll-fed labelers are easier to operate, change-over and maintain than larger rotary labelers because they are less mechanically complicated. The simplicity of the linear roll-fed design, and the smooth operation of B & H's patented Constant Velocity Starwheel System, drive this important advantage. BH1600AB labelers also have a substantially smaller footprint than rotary labelers which saves valuable floor space. For customers that already own BH1600 labelers, adding a new BH1600AB reduces switching costs because change parts and a majority of spare parts are compatible.

BUILT TO LAST

Unlike other low-priced labelers, the BH1600AB does not cut corners on key machine components. Their durability starts with a rugged, welded, and stress-released frame which minimizes vibration and provides a precisely engineered platform which supports the precise alignment of key machine components. Stainless steel lower guarding and labeler table tops resist corrosion, even in wet environments, and contribute to the long useful life of this popular line of labelers.

NICELY EQUIPPED, NOT STRIPPED

The BH1600AB also does not cut corners on standard features. Components that are upcharge options on other low priced labelers are standard features on a BH1600AB. For example, a servo driven registration control system is standard equipment on a BH1600AB. A built-in air conditioner is also standard equipment. Take time to compare, and the value offered by the BH1600AB makes it one of the smartest buys in labeling equipment.

DESIGNED WITH THE OPERATOR IN MIND

The Allen-Bradley touch screen interface of the operator control station combined with B & H's patented constant velocity starwheel system simplifies machine set-up. The touch screen displays feature easy system navigation and password security, and dedicated screens are provided for container and label parameters, alarm history, and system troubleshooting. Together these features help the operator get and keep the labeler running.



B & H's patented constant velocity starwheel system is standard on BH1600AB labelers.

BH1600AB HIGHLIGHTS

- Everyday production speeds of 60 to 450 cpm
- Allen-Bradley controls standard
- Patented constant velocity starwheel system provides smooth, efficient container handling
- Durable and dependable operation with a long useful life
- Small footprint minimizes expensive factory floor space requirement
- Servo driven registration control system is standard
- Rapid Change Over (RCO) change parts offer 45 minute size changeovers
- Intuitive color touchscreen controls provide secure, user-friendly operation
- Proven BH1600 cutters offer dependable performance and cutter bearing oil baths extend the life of the cutter
- Temperature-controlled glue roller with micro-adjust feature minimizes adhesive stringing, even at high speeds

CONTACT US

sales@bhlabeling.com
+1.209.556.6160

B & H LABELING SYSTEMS

3461 Roeding Road
Ceres, CA 95307
USA

www.bhlabeling.com



INNOVATION FOR THE LONG RUN®

BH1600AB

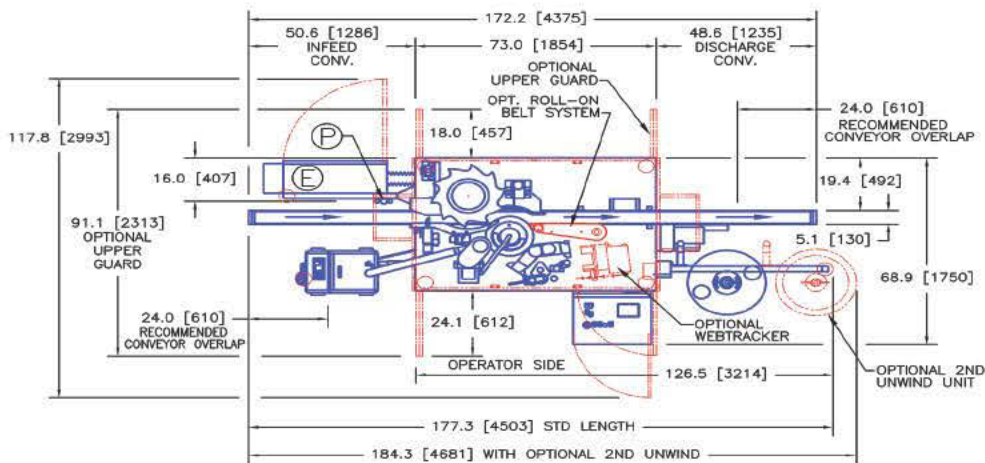

BH1600AB SPECIFICATIONS⁺

Speed Range*:

Base model:
60 – 200 CPM (containers per minute)

With roll-on belt:
60 – 350 CPM

With roll-on belt and Invation Passive Starwheel:
60 – 450 CPM

Container Handling:

B & H's patented Constant Velocity Starwheel System

Container Diameter Range:

Label Panel Diameter Range
1.98 – 5.70 in (50 – 145mm)

Label Size Range:

Length (for complete wrap):
6.5 – 18.4 in (165 – 467 mm)

Width:
1.0 – 9.5 in (25.4 – 241 mm)

Container Materials:

Plastic, glass, metal, fiberboard

Label Materials:

Paper, PE, BOPP, PVC, PE, and PS, in single and multi-layer structures

Ambient Operating Conditions:

Temperature: 50° – 120° F (10° – 49° C)
Relative Humidity: 10 – 90%, non-condensing

Electrical:

Main voltage: 380 - 480 VAC; 3 phase; 30 amps
Control voltage: 24 volts

Air:

80 PSI (551 KPa) via 0.5" NPT;
Consumption approximately 15 CFM

Conveyor:

Straight-through, left-hand infeed, stainless steel, left or right side transfer

Conveyor Height:

Adjustable 36.5 in to 39.0 in (927 mm – 991 mm)

⁺ Specifications subject to change without notice.

* Labeling speed is dictated by cutter configuration, container type, container shape and line conditions.

B & H LABELING SYSTEMS

3461 Roeding Road
Ceres, CA 95307
Tel: +1.209.556.6160
Fax: +1.209.537.6854
www.bhlabeling.com
sales@bhlabeling.com



GENERAL FEATURES

CONVEYOR: straight-through conveyor configuration, stainless steel, left hand feed

TABLETOP & LOWER GUARDING: stainless steel

UPPER GUARDING: swing out, polycarbonate doors with safety interlocks are an available option

MAIN DRIVE SYSTEM: 3 HP AC variable speed motor with frequency control & mechanical safety clutch

DRIVE CHAIN: heavy duty gear chain

PLC: Allen-Bradley

HOT-MELT SYSTEM: Nordson re-circulating, continuous flow

VACUUM SYSTEM: multi-valve system with independent controls

ELECTRONIC ENCLOSURE: NEMA 12, built-in air conditioner

OPERATOR CONTROL STATION: Allen-Bradley color touchscreen

CHANGE PARTS: color coded, Rapid Changeover (RCO) change parts standard

LUBRICATION: manual, centralized

CONTAINER HANDLING FEATURES

CONTAINER INFEED: patented Constant Velocity Starwheel System for smooth container handling and fast changeovers

AUTOMATIC LINE SPEED CONTROLS: automatic adjustment of machine speed based on container supply at infeed and discharge

MISSING CONTAINER DETECTION & ALARMS: stops labeler when missing container detected at high speed

ROLL-ON-PAD: fine adjustment for pitch control

LABEL HANDLING FEATURES

REGISTRATION CONTROL: Servo driven system standard

LABEL ROLL STANDS: single label roll stand with mechanical brake standard

LOW REEL ALARM: detects low reel status and automatic alarm notifies operator; label countdown capability allows operator to minimize butt-roll label scrap

BROKEN WEB SAFETY & ALARM: detects broken web condition and automatically shuts down labeler

VACUUM DRUM SAFETY & ALARM: detects missing label on vacuum drum and automatically stops labeler

OPERATOR INTERFACE

ALARM SCREEN: displays current and past alarms, with reset function

TROUBLE SHOOTING DISPLAYS: for faster problem diagnosis

CONTAINER & LABEL SET-UP RECIPES: for faster size changeovers

AVAILABLE OPTIONS

SECOND LABEL ROLL STAND

WEBTRACKER

ROLL-ON BELT SYSTEM

INVATION PASSIVE STARWHEEL SYSTEM

UPPER SAFETY GUARDING

ELECTRICAL ROLL STAND BRAKING SYSTEM

REMOTE ACCESS MODULE

ADDITIONAL SETS OF RCO CHANGE PARTS

CONTACT B & H FOR A COMPLETE LIST OF AVAILABLE OPTIONS

SPARE PARTS KIT