

INVATION™ CUTTER 2.0

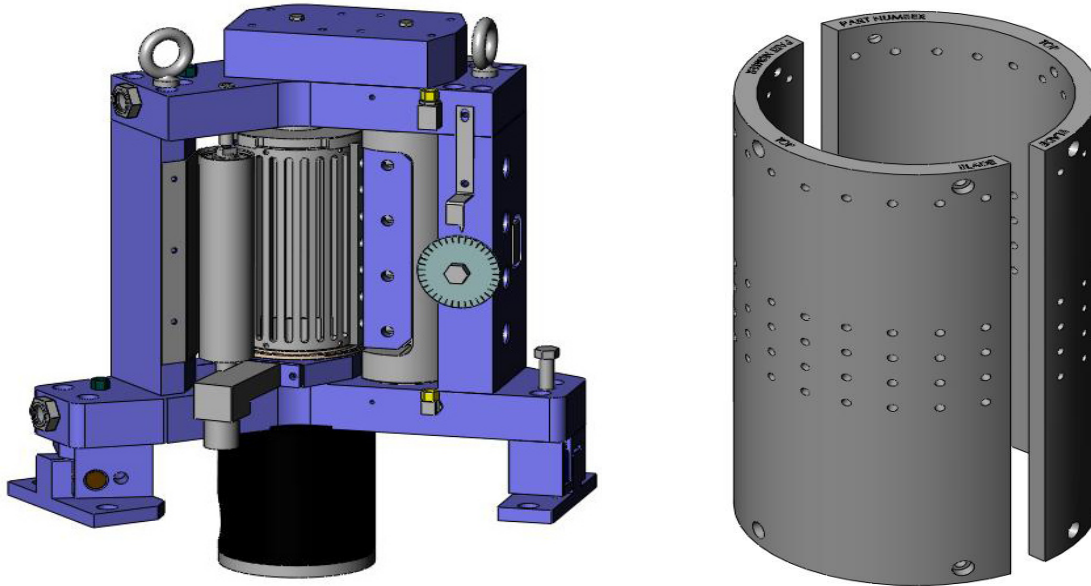

(Marathon Invation™ Cutter 2.0 with shells removed is shown. Cutter shells are not to scale.)

The Invation™ Cutter 2.0 is the latest cutter design from B & H Labeling Systems. Offered in three and four station configurations, Invation cutters are available options on new Marathon labels, and they are also offered as aftermarket upgrades for installed Marathon labels. These high performance cutters are designed to deliver smooth high speed operation, improved label handling capabilities, and low maintenance requirements.

INVATION™ CUTTER 2.0

The Invation Cutter 2.0 is the latest model in the Invation Cutter series. This updated version of the Invation Cutter retains the rotary shear head suspension system and the improved vertical vacuum flow channels of the original design. The key new features of 2.0 include thicker cutter shells with two finish options: hard anodized and the high performance Kineti-Coat™ low coefficient of friction (COF) finish. It also features new top and bottom cap designs which offer easier and faster shell removal and replacement.

DURABLE AND DEPENDABLE

All Invation Cutters employ principles of operation based on the classic vacuum controlled, single rotary blade and single stationary blade technology invented by B & H. The Invation Cutter 2.0 represents the continued evolution of this proven, dependable, and durable design. Available in three and four station configurations, Invation Cutters are recommended for high speed applications and for production environments that run a wide variety of labels, labels with variable COF characteristics, or stretch prone labels.

KINETI-COAT™ CUTTER SHELL FINISH

Kineti-Coat is a proprietary, low COF cutter shell finish that is an available option on Invation Cutter shells. This finish dramatically widens the window of operation for label materials, particularly for label materials with high or variable coefficients of friction. Kineti-Coat's low COF finish creates a wider window of operation that makes it possible to run many label materials that will simply not run on current cutters. The finish also makes it possible to run challenging materials at higher speeds than are possible using current cutters.

TOTAL FINANCIAL IMPACT

Total financial impact is all about maximizing production output and minimizing operating expense. Invation Cutters deliver optimum total financial impact by reducing downtime, increasing operating efficiencies, increasing production speeds, reducing maintenance expenses, and extending the useful life of valuable capital assets. All of these impacts can be quantified for your operation using B & H's Total Financial Impact tool and analysis process.

AFTERMARKET UPGRADE

The Invation Cutter 2.0 is available on new Marathon labelers and as an aftermarket upgrade for installed Marathon labelers. The field installation of a new Invation Cutter can be completed by a B & H Field Engineer in less than one day. The cutter is also compatible with existing Marathon change parts, with the exception of existing cutter shells. All existing cutter shells must be replaced as part of the upgrade.

REBUILD AND TRADE-IN OPTIONS

Existing Marathon Invation Cutters can be rebuilt in our Ceres facility. With this option, customers buy new cutter shells, rent and install a loaner cutter, and ship their current cutter to B & H. The rebuilt cutter is then installed on the labeler, and the loaner cutter is returned to B & H. B & H also offers a trade-in discount for Marathon Invation Cutters.

CONTACT US

For more information on Invation Cutters, contact your B & H Regional Sales Manager or simply call B & H at 209-537-5785. To order an Invation Cutter for installed Marathon labelers, contact your dedicated B & H Inside Sales Coordinator at 209-537-5785 or e-mail your inquiry to parts@bhlabeling.com.

THE INVATION™ CUTTER 2.0 HIGHLIGHTS

- Best in class cutter technology from B & H
- Latest model in the Invation Cutter series, launched August 2010
- Available option on new Marathon labelers
- Aftermarket upgrade for installed Marathon labelers
- Rebuild program and trade-in allowances available for installed Marathon Invation Cutters
- Twin cutter shells are custom designed for every container and label combination - no more taping vacuum holes on the cutter
- Optional Kineti-Coat™ low COF cutter shell finish widens window of operation for hard to run label materials
- Improved cut accuracy, longer blade and bearing life, superior vacuum control and lower maintenance requirements than non-Invation cutters
- When paired with Marathon's intelligent registration control system, the Invation Cutter contributes to higher production speeds, less downtime and higher productivity
- BH8000 version planned for 2011

“INNOVATION FOR THE LONG RUN®”

